

POWER tech
distribuzione



POWER tech
distribuzione

Benzinmotoren OHV

Gasoline engines

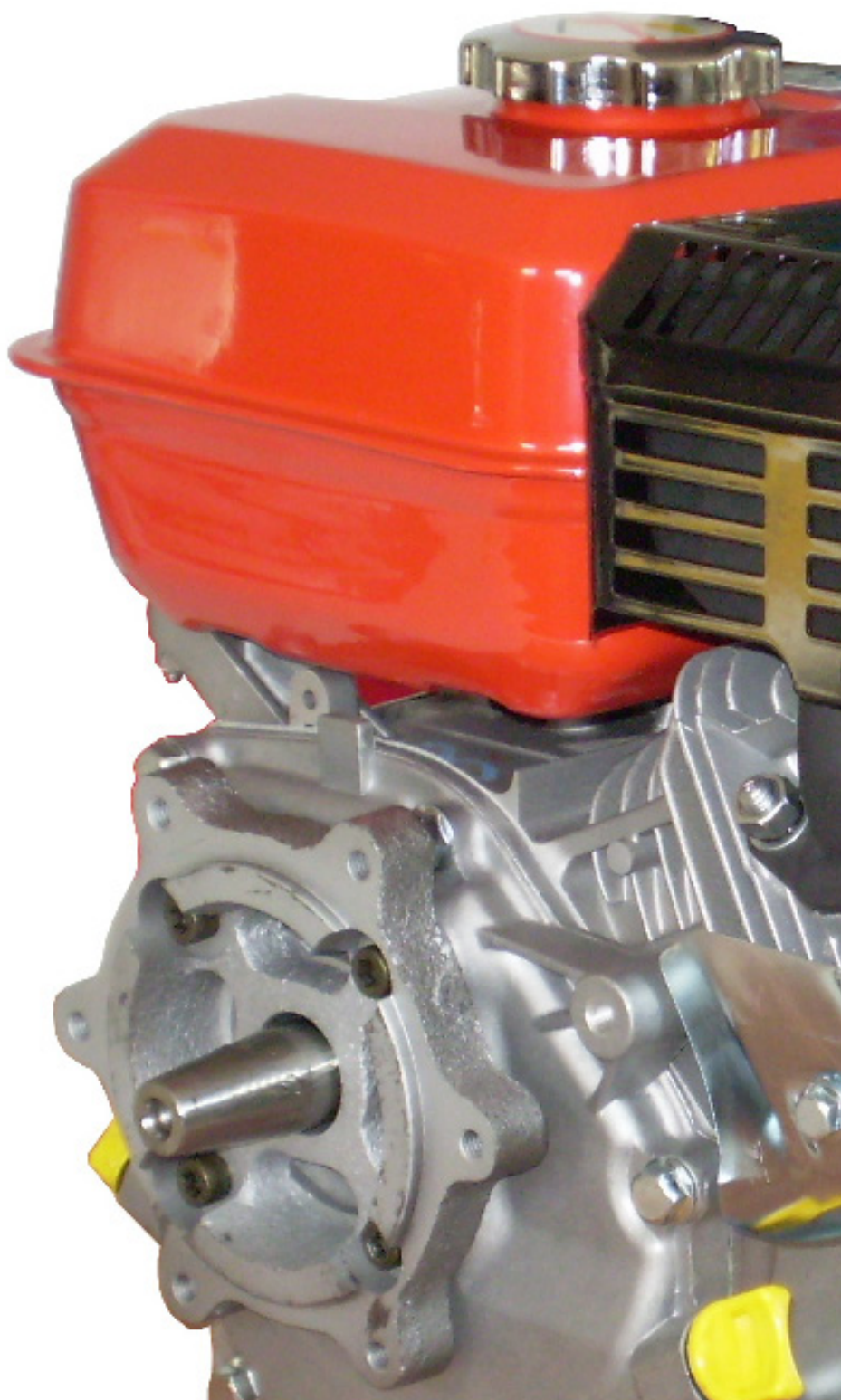

Benzinmotoren mit OHV

Gasoline engines with over head valves

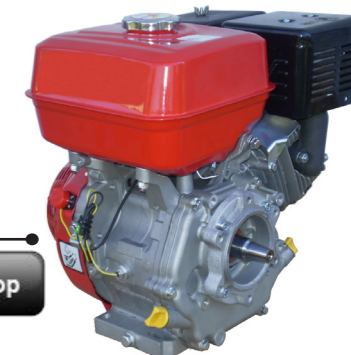
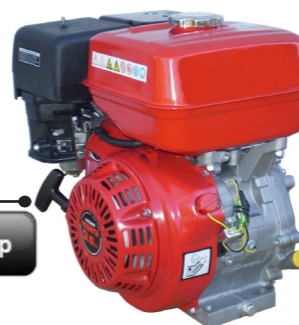
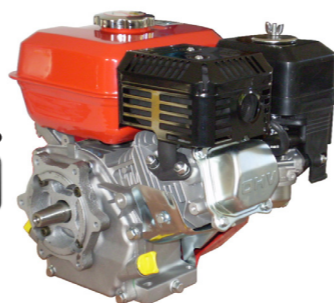

Motortyp / Engine type:

		Y 130	Y 170	Y 210	Y 260	Y 280	Y 360	Y 410
Zylinder / Cylinder	N.	1	1	1	1	1	1	1
Bohrung / Bore	mm	62	70	70	75	79	84	90
Hub / Stroke	mm	42	45	54	58	58	64	64
Hubraum / Displacement	cm ³	127	173	208	256	284	355	407
U/Min. / RPM		3600	3600	3600	3600	3600	3600	3600
Max. Kw-PS / Max rating Kw/Hp	Kw/PS	3.0 - 4,2	4,2 - 5,7	4,9 - 6,7	6,2 - 8,5	6,9 - 9,5	8,4 - 11,5	9,9 - 13,5
Max. Torque / Max torque	Nm/Kgm	7,4 - 0,75	10,8 - 1,10	13,2 - 1,35	16,7 - 1,7	19,1 - 1,9	23,5 - 2,4	26,5 - 2,7
Min. Benzinverbr. / Min. specific fuel consumpt.	g/kWh-g/Hph	300 - 230	313 - 230	313 - 230	313 - 230	313 - 230	313 - 230	313 - 230
Tankinhalt / Tank capacity	L	2,5	3,5	3,5	6,0	6,0	6,5	6,5
Ölfüllmenge / Oil saum capacity	L	0,56	0,60	0,60	1,1	1,1	1,1	1,1
Ölfüllmenge Kupplung/ 1/2R oil clutch riduction capacity	L	0,50	0,50	0,50	0,3	0,3	/	/
Trockengewicht / Dry weight	Kg	12	15	16	23	23	31	31
Abmessungen / Overall dimensions	mm	297 x 341 x 318	312 x 362 x 335	312 x 362 x 335	380 x 430 x 410	380 x 430 x 410	405 x 450 x 443	405 x 450 x 443

ABTRIEBSWELLEN FÜR MOTOREN Y130 - 170 - 210 SHAFT TYPE FOR ENGINES Y130 - 170 - 210

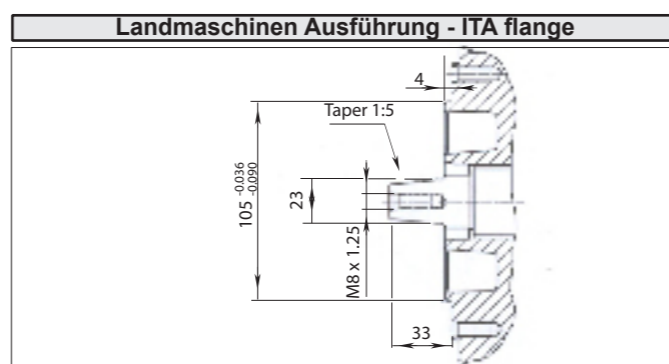
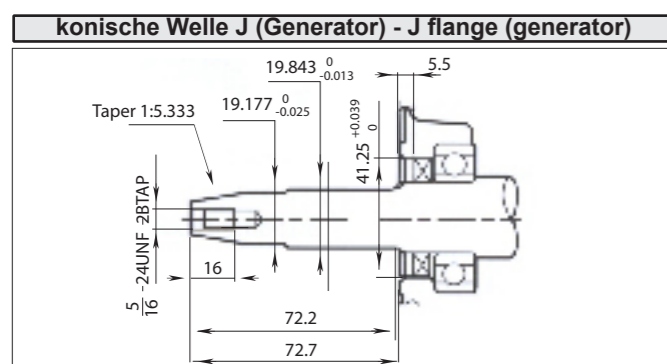
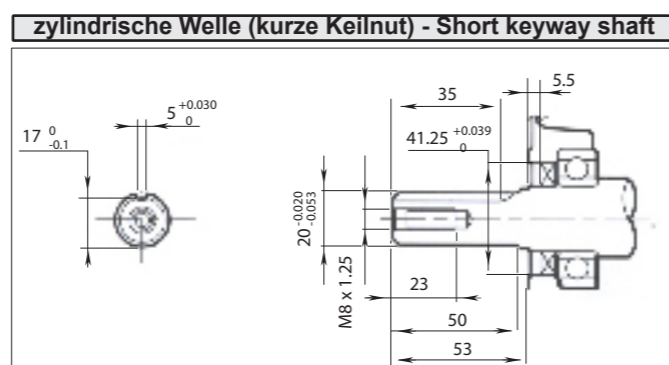
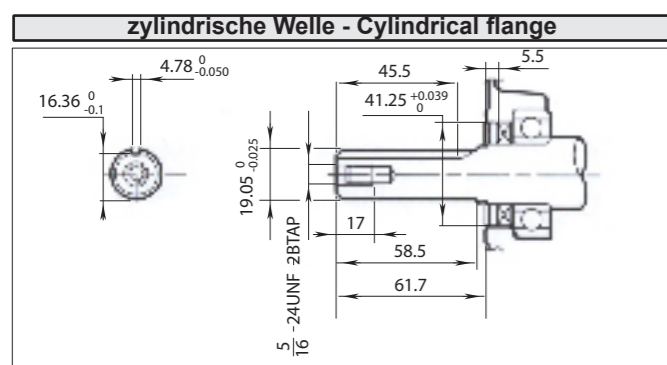

ABTRIEBSWELLEN FÜR MOTOREN Y260-280-360-410 SHAFT TYPE FOR ENGINES Y260-280-360-410

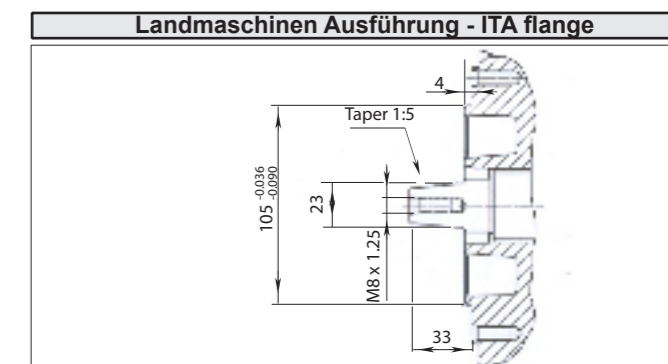
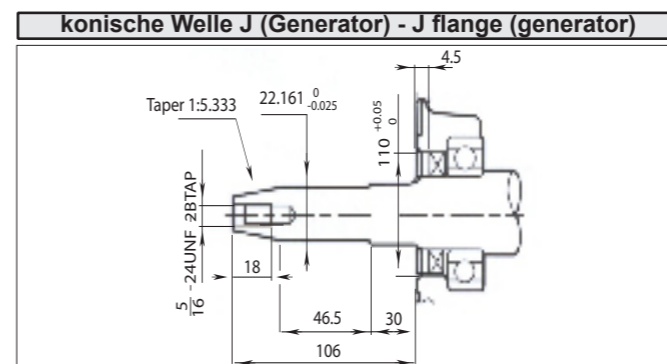
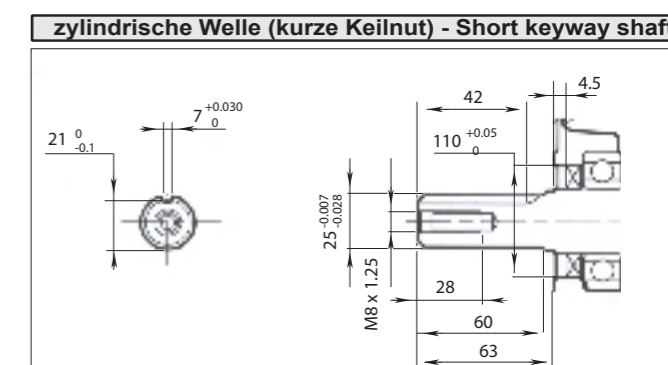
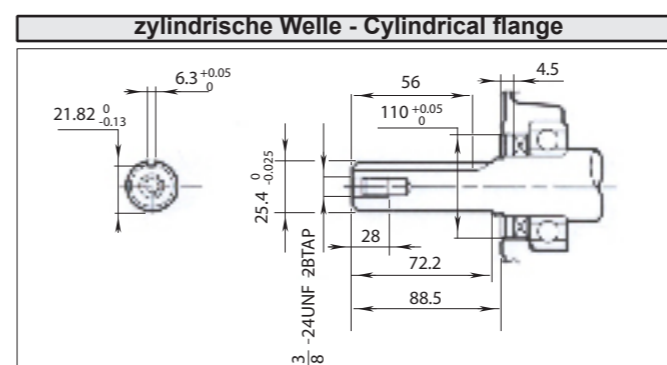

Benzinmotoren mit Reduktionsgetriebe - Gasoline engines with 1/2 reduction gear

Abtriebswelle / Pto shaft dimensions

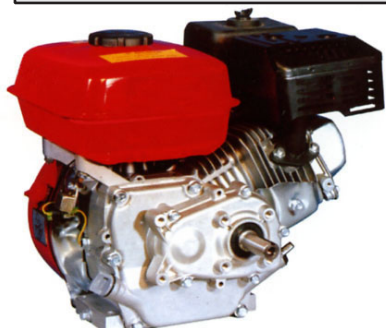

Y 130R Y 170R Y 210R

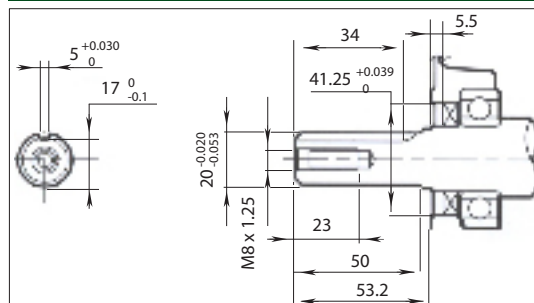

Y 280R Y 360R Y 410R

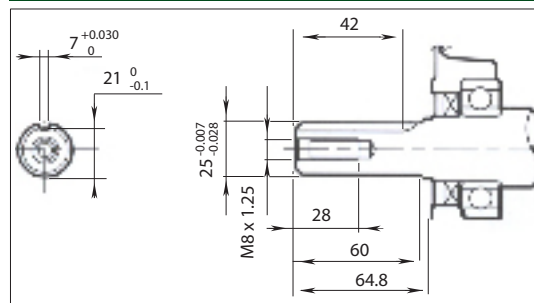

Motortyp / Engine type:

Y 170-1/2R

Y 210-1/2R

Y 270-1/2R

Y 360-1/2R

Y 410-1/2R

Hubraum / Displacement	173 cc	208 cc	284 cc	355 cc	407 cc
U/Min. / RPM	1800	1800	1800	1800	1800
Max. Leistung Kw-Cv / Max rating Kw/Hp	4.2Kw / 5.7 HP	4.9Kw / 6.7 HP	6.9Kw / 9.5 HP	8.4Kw / 11.5HP	9.9Kw / 13.5 HP
Tankinhalt / Tank capacity	3.5 L	3.5 L	6 L	6.5 L	6.5 L
Ölfüllmenge / Oil sump capacity	0.6 L	0.6 L	1.1 L	1.1 L	1.1 L
Trockengewicht / Dry weight	Kg 20	Kg 20	Kg 30	Kg 30	Kg 30

Benzinmotoren mit Reduktionsgetriebe und Kupplung - Gasoline engines with 1/2 reduction gear with clutch

Abtriebswelle / Pto shaft dimensions

Y 170 1/2R - Y 210 1/2R - Y 280 1/2R

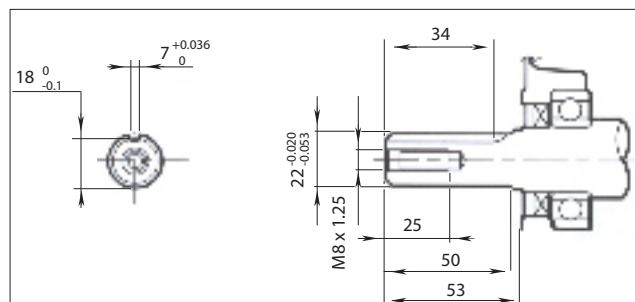

Motortyp / Engine type:

Y 210-1/2R

Y 280-1/2R

Hubraum / Displacement	208 cc	284 cc
Abtrieb U/Min. / Pto RPM	1800	1800
Max. Leistung Kw-Cv / Max rating Kw/Hp	4.9Kw / 6.7 HP	6.9Kw / 9.5 HP
Tankinhalt / Tank capacity	3.5 L	6 L
Ölfüllmenge Motor / Oil sump capacity	0.6 L	1.1 L
Ölfüllmenge Kupplung / Oil riduc. capacity	0.5 L	0.3 L
Trockengewicht / Dry weight	Kg 20	Kg 30

Benzinmotoren mit vertikaler Abtriebswelle - OHV gasoline engines with 1/2 vertical shaft



Motortyp / Engine type:

SPV120

SPV160

Hubraum / Displacement	118 cc	163 cc
U/Min. / RPM	3600	3600
Max. Leistung Kw-Cv / Max rating Kw/Hp	2.9Kw / 4.0 HP	4.0Kw / 5.5 HP
Tankinhalt / Tank capacity	1.1 L	2.1 L
Ölfüllmenge / Oil sump capacity	0.56 L	0.6 L
Trockengewicht / Dry weight	12 Kg	13.5 Kg